

IMPORTANT

24 HR WATER TEST INSTRUCTIONS

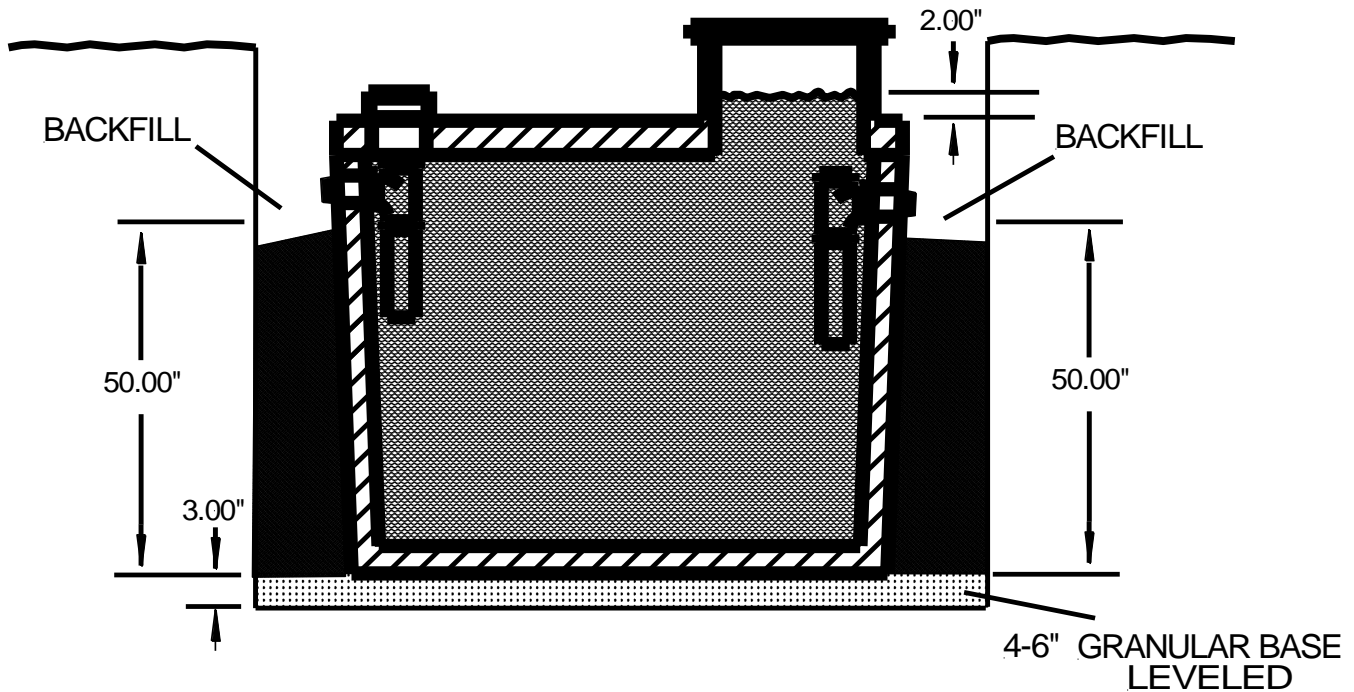

1. Plumbing should be inserted 7.5" starting from the rubber baffle.
2. Backfill 50 inches deep from bottom of tank all around.
3. Plug inlet and outlet AT TANK so tank is isolated from other parts of system.
4. Fill tank with water so there is two inches of water in riser. No more, no less.

NOTE: IF YOUR INSPECTION IS ON A MONDAY, FILL TANK TO SEAM AND FILL REMAINDER OF TANK 24 HOURS BEFORE INSPECTION

5. Measure the water loss; if there is no water loss during the first 24 hours the test is acceptable.
6. More than a one gallon water loss during this time is cause for rejection.

NOTE: IN HOT WEATHER CONCRETE WILL ABSORB WATER, REFILL AND RETEST IF LEVEL DROPS

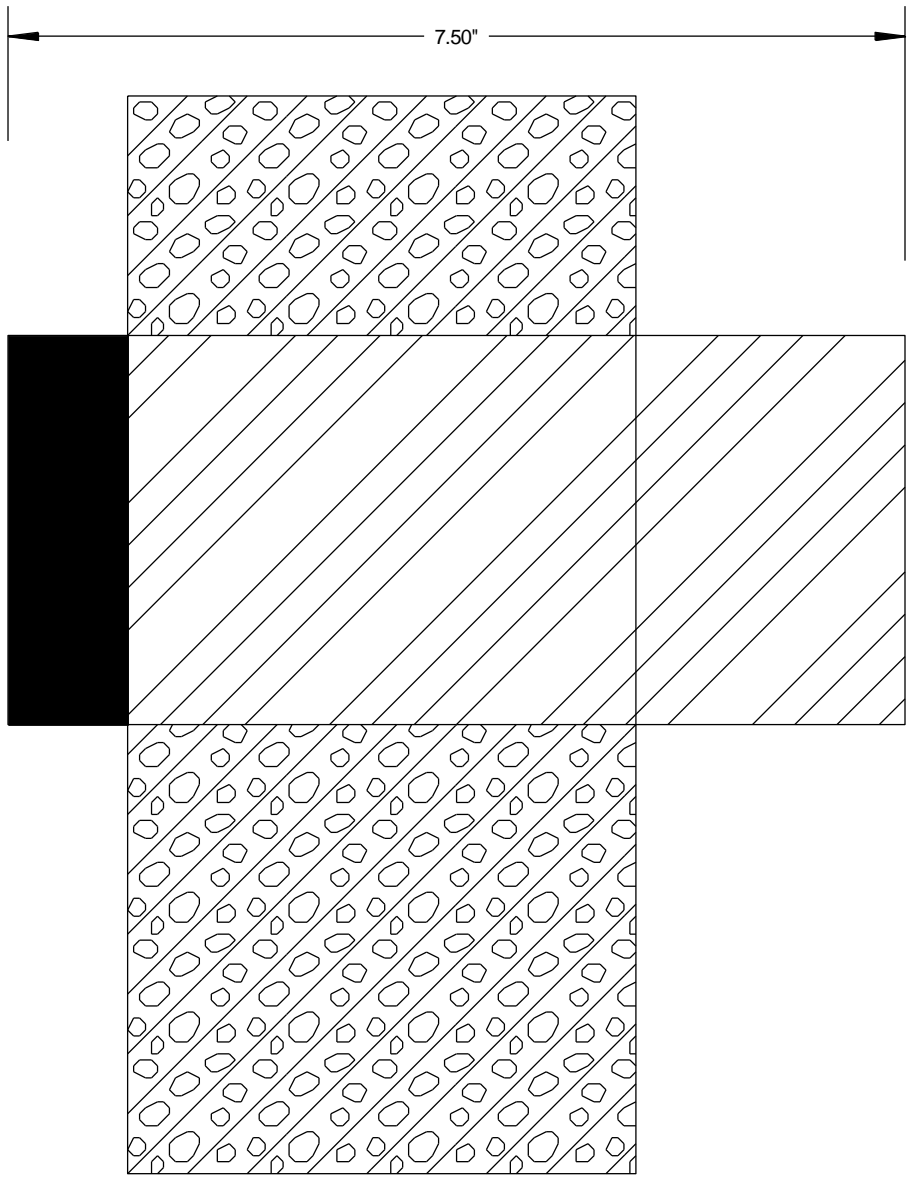

PIPE SHOULD BE INSERTED 7.5" STARTING FROM THE RUBBER BAFFLE